



**PS** Flood Barriers™

# AQUATRIGGER™

*Automatic Flip-Up Flood Barrier*

**FLUSH PROFILE!**



Independent-Party  
Validated



Ease Of Install

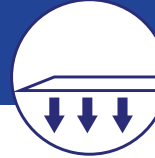

Self-Stores,  
Pivots Open

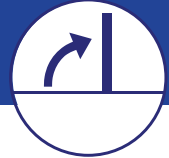

Deployed Electronically,  
Manually Or Passively

## AQUATRIGGER™ AUTOMATIC FLIP-UP FLOOD BARRIER (BH-590)

*PIVOTAL FLOOD PROTECTION THAT STAYS HIDDEN, DEPLOYING AUTOMATICALLY WHEN NEEDED*

It's never been easier to keep your property safe from flooding, thanks to the AquaTrigger™ Automatic Flip-Up Flood Barrier. This flood protection solution self-stores flush with a walk/drive surface. It is AASHTO H-20 / HS-20 load rated for large truck traffic, and if flooding occurs, the water's hydrostatic pressure causes the barrier to automatically pivot up, providing water protection up to eight feet in height. In addition to being passively activated, this barrier can also be manually or electronically deployed. It's ideal for commercial applications, including driveways/walkways, storefronts, exterior door openings and loading docks.

**ALWAYS READY** - Providing up to eight feet of water protection height, this barrier is always in place and deploys before water reaches ground level. It can also be deployed electronically or engaged manually by lifting the counterbalanced panel.

**HIGHER LOAD RATING THAN EVER BEFORE** - This barrier is engineered to the AASHTO H-20 / HS-20 load rating for large truck traffic and independent-party validated, meeting the requirements of the ANSI / FM Approvals 2510-2020 4.3.3 Hydrostatic Test.

**NO TRIPPING HAZARDS** - The barrier self-stores flush with a walk/drive surface for unimpeded traffic passage without creating any tripping hazards.

**IDEAL FOR A VARIETY OF APPLICATIONS** - The AquaTrigger Automatic Flip-Up Flood Barrier protects buildings from water infiltration through exterior building openings, protects openings in floodwalls and provides spill containment to keep chemical spills or sprinkler releases from spreading throughout your facility or harming the environment. It is custom-engineered to fit your facility and flood loads.

**ALL CORROSION-RESISTANT CONSTRUCTION** - Featuring an all-aluminum panel and basin, this barrier includes stainless steel and coated steel fasteners and components, as well as UV- and chemical-resistant flood seals. In addition, the gaskets are hidden when in the stored position, which protects them from weathering, UV exposure and vandalism.

**QUICK AND SIMPLE INSTALLATION** - The AquaTrigger Automatic Flip-Up Flood Barrier requires minimal below-grade depth (approximately 8.5" for installation clearance). It ships as a fully assembled unit and most sizes can be installed in a prepared site on the same day as delivery.

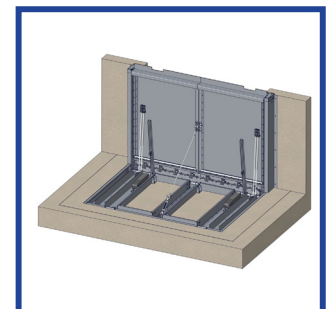
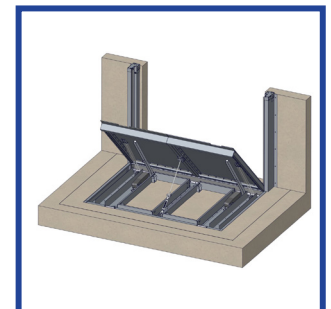
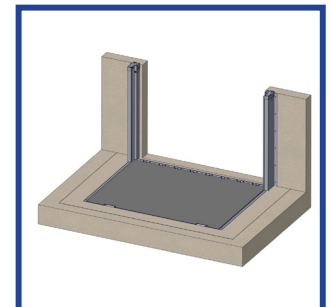

R070722