

Step 1

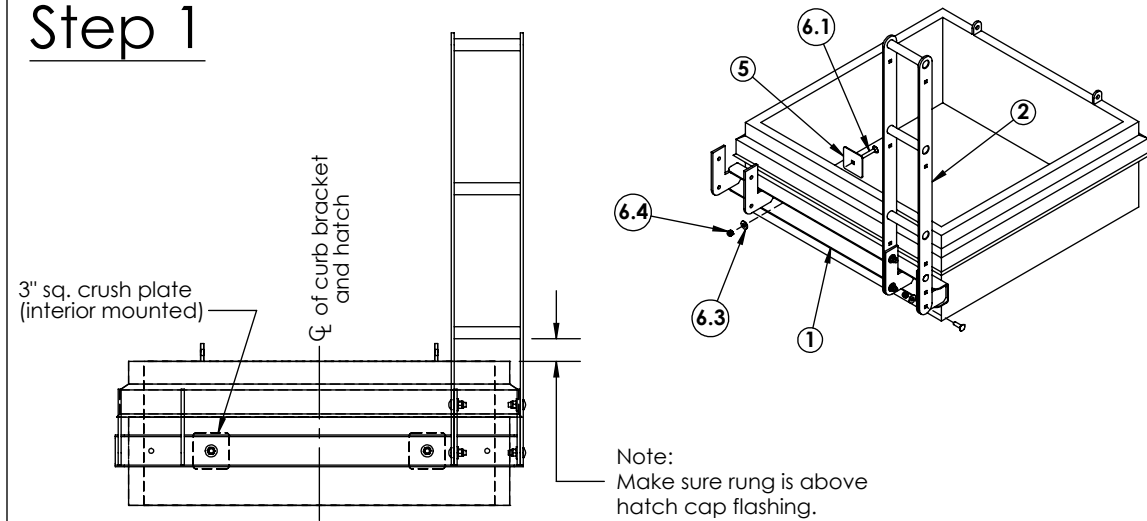

When determining the height of the bracket, keep in mind the bottom rung must be higher than the top of the hatch (see drawing above). It may be of assistance to loosely attach one of the vertical rung assemblies to the curb bracket and get a rough estimate of the height desired. The vertical bracket has a series of holes, therefore final adjustment can be made once the curb bracket has been installed. Once the height has been determined, mark the holes to be used for fastening to the existing hatch (2 locations). Choose the holes closest to the edge of the hatch, this will strengthen the assembled Hatch Grip. Keep in mind that the 3" sq crush plate must be mounted to the interior so you will have to allow for clearance. Before fastening the curb bracket, make sure the provided adhesive backed EPDM seal is at each anchor point (between the curb bracket and existing hatch) to eliminate outside elements.

Step 2

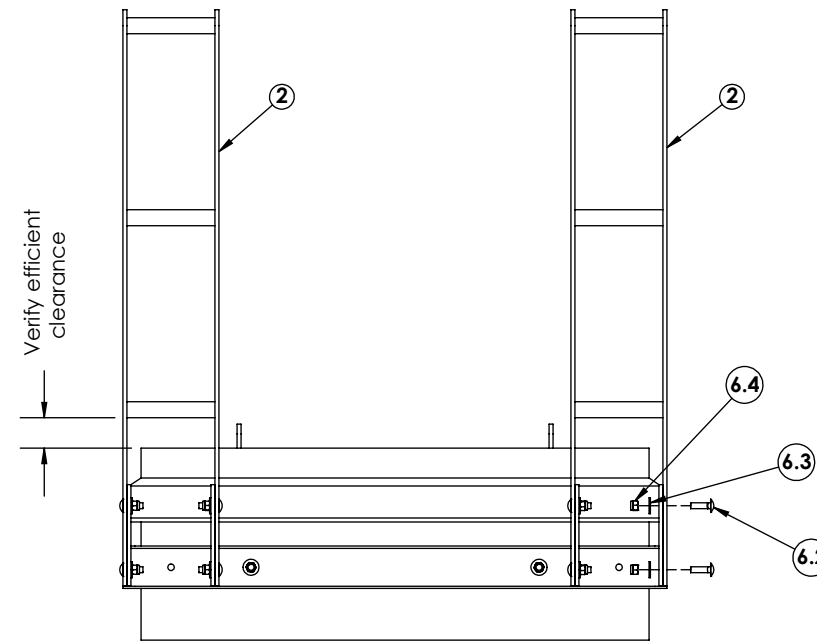

Once the curb bracket has been attached to the hatch, you can now fasten the vertical rung assemblies to the curb bracket with the provided 3/8"-16 x 1-1/4" carriage bolts. At this point, you can make any final height adjustments by using any two holes supplied on the vertical rung assemblies (4 bolts per rung assembly).

Step 3

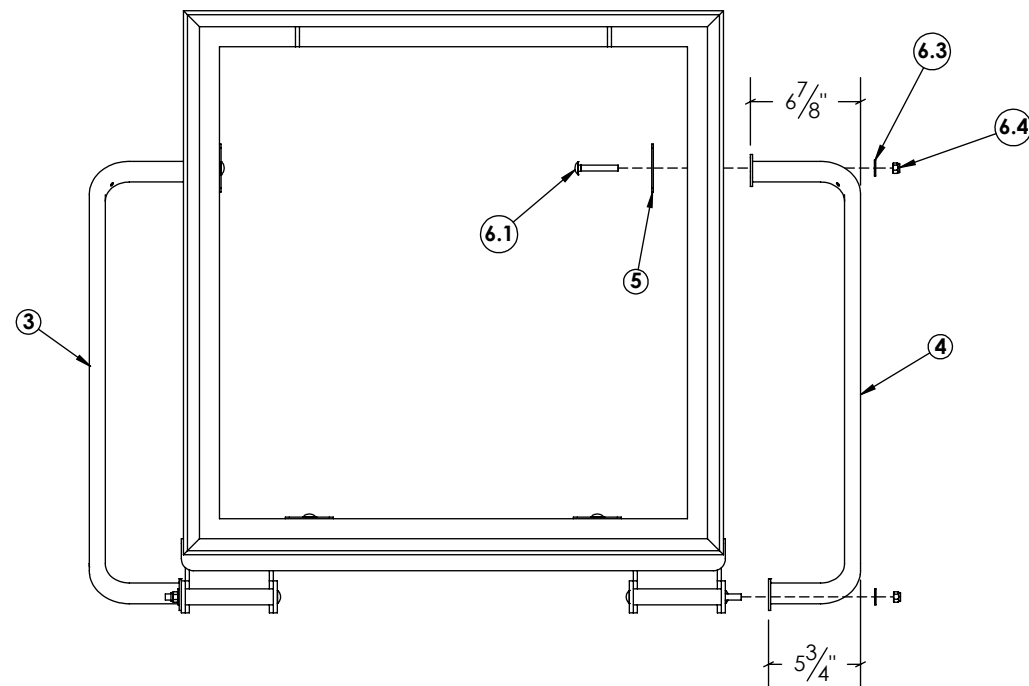

The next step is to attach the support tube rails. The length of both legs of the support tube rails (see drawing) are different lengths, this is to accommodate various sizes of roof hatches. Determine which configuration will work best for your application (simply rotate if required).

Step 4

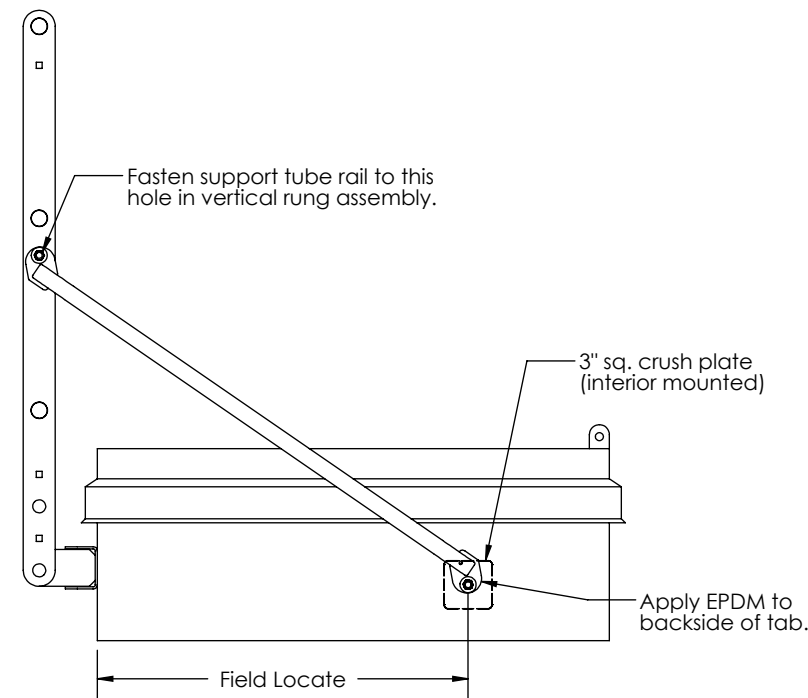

Fasten the support tube rail to the existing hole in the vertical rung assembly (see drawing) with the provided 3/8"-16 x 1-1/4" carriage bolts. Position the other end at the desired location (mount as far back as possible). Before fastening to the hatch, apply the adhesive backed EPDM seal to the back side of the support rail tab. Blocking out (by others) of the support tube rail may be required depending on hatch design.

PS DOORS

**HTG-PCG
Hatch Grip PCG**

Finish: Powder Coated Textured Gray

1150 48th St. S
GRAND FORKS, ND 58201
PH. 887-446-1519
FAX 701-746-8340

Patent Numbers: 6,095,283;
6,347,685; 6,619,428

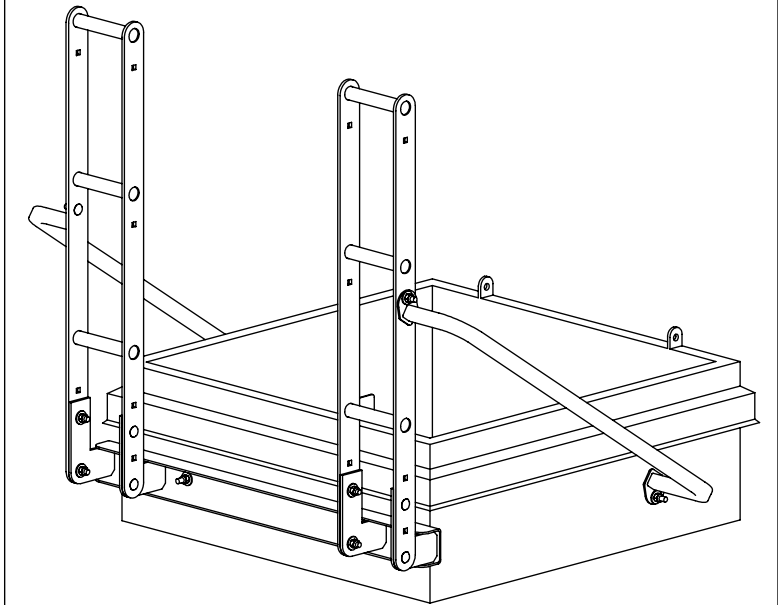

Bill of Materials for One (1) Hatch Grip

ITEM	PART NUMBER	DESCRIPTION	QTY.
1	500801	HTG;Assy Curb Brkt PCG	1
2	500802	HTG;Assy Rung PCG	2
3	500803	HTG;Assy Supp Tube Right PCG	1
4	502172	HTG;Assy Supp Tube Left PCG	1
5	500807	HTG;Crush Plate PCG	4
6	502077	HTG; Hardware Bag	1
6.1	500320	Bolt;Carriage 3/8" 1 6x2-1/2 Gr5 Zn	4
6.2	500318	Bolt;Carriage 3/8" 1 6x1-1/4 Gr5 Zn	10
6.3	501947	Washer; Flat 3/8" Zn	14
6.4	501120	Nut; Nylock 3/8" 1 6 Zn	14

* **Hatch Grip** is not intended to act as a protective barrier for guarding the open roof hatch. For complete fall protection guarding of an open roof hatch see our **HatchSAFE** product.

If you need clarification or technical advice, please feel free to contact our office at 1-800-284-0623. Our offices are open 8:00 AM to 5:00 PM, CST, Monday through Friday.